

◆ CELL CHARACTERISTICS

Capacity	Typical	35Ah 130Wh
	Nominal	3.7V
Nominal voltage	Charge	4.2V
	Discharge	2V
Charge current	Standard	15A
	Maximum	210A
	Peak (10s)	1120A
Charge time	Standard	120min
	Fast charge	12min
Discharge current	Standard	15A
	Maximum	420A
	Peak (10s)	1225A
Internal Resistance	AC (1 kHz)	<0.4mΩ
Ambient temperature	Charge	0 to 60°C
	Discharge	-30 to 60°C
Energy Density	Volumetric	180Wh/L
	Gravimetric	105Wh/kg

◆ PHYSICAL CHARACTERISTICS

Shape	Prismatic
Can	Al 3003
Dimensions:	
L	148.6±0.3mm
H	105.3±0.3mm
W	52.3±0.3mm
Weight	1300g

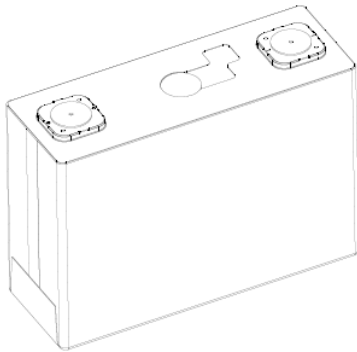

◆ DISCHARGE RATE CHARACTERISTICS

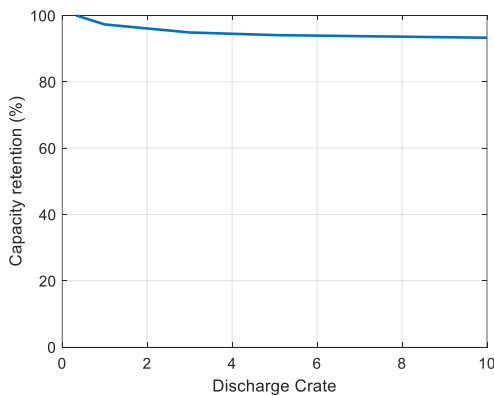

◆ DISCHARGE TEMPERATURE CHARACTERISTICS

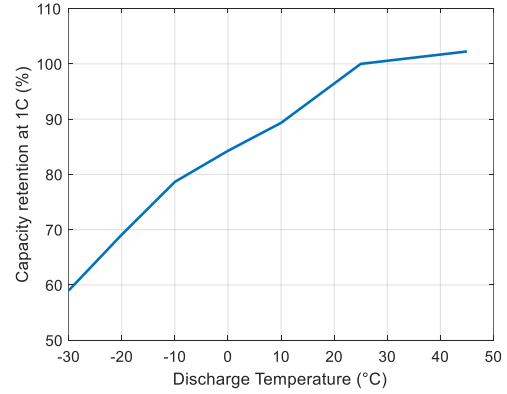

◆ CHARGE RATE CHARACTERISTICS

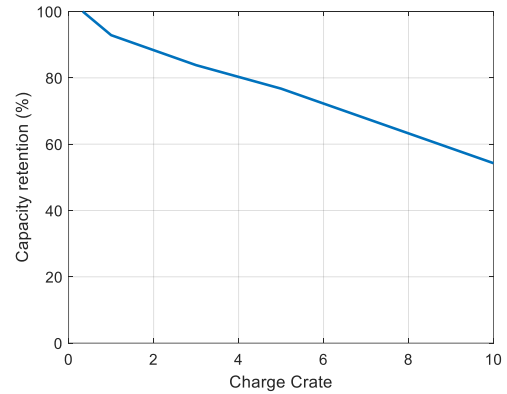

◆ LIFETIME PERFORMANCES

